

**This electronic collection of documents is provided
for the convenience of the user
and is Not a Certified Document –**

**The documents contained herein were originally issued
and sealed by the individuals whose names and license
numbers appear on each page, on the dates appearing
with their signature on that page.**

**This file or an individual page
shall not be considered a certified document.**

09/08/19

TIP PROJECT: B-4410A

TIP NO.	SHEET NO.
B-4410A	UC-1

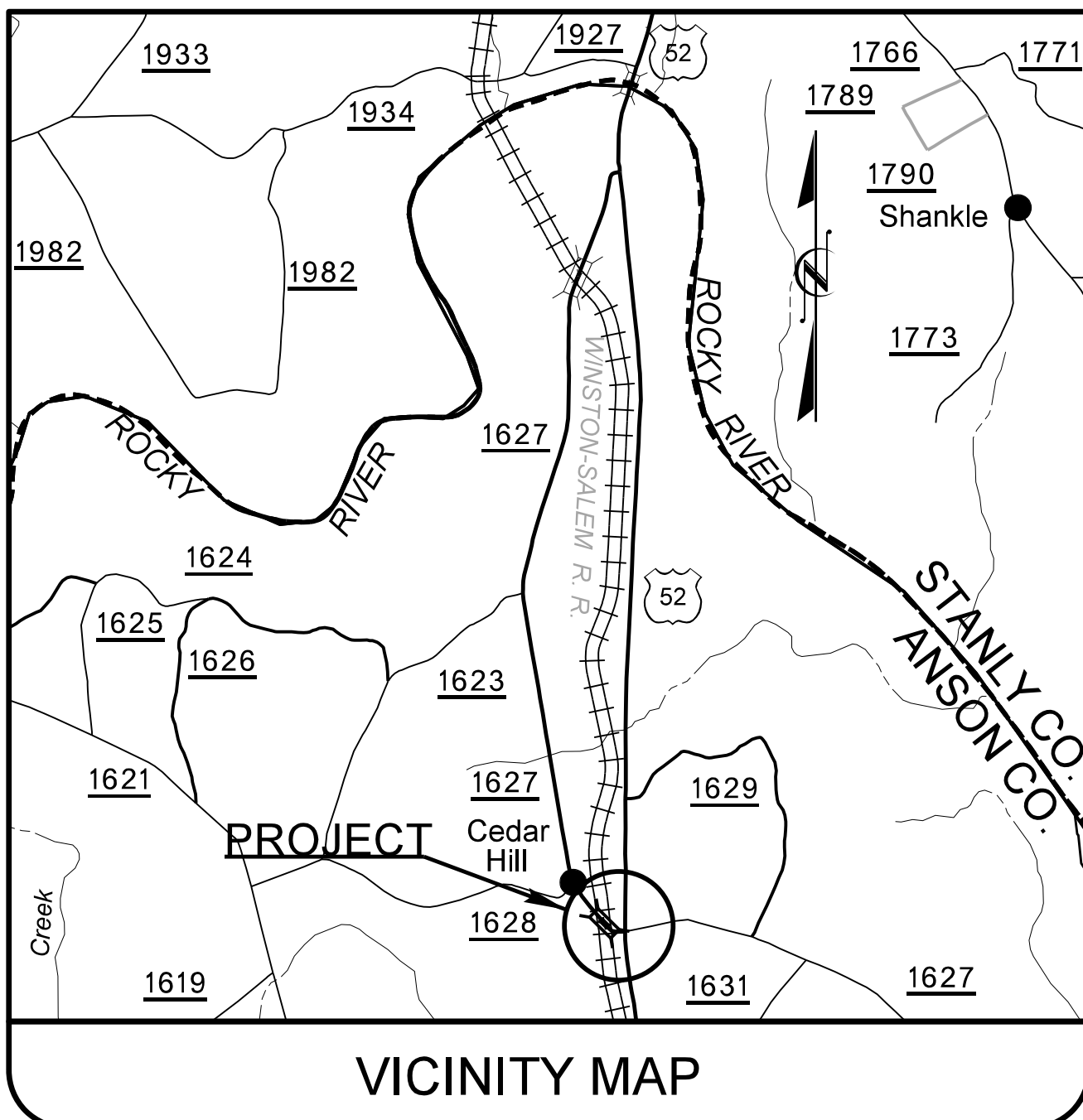

STATE OF NORTH CAROLINA
DIVISION OF HIGHWAYS

UTILITY CONSTRUCTION PLANS ANSON COUNTY

**LOCATION: PINKSTON RIVER ROAD (SR-1627) FROM
200' WEST OF BRIDGE NO. 307 OVER THE
WINSTON-SALEM SOUTH BOUND RAILROAD TO US 52**

TYPE OF WORK: WATER LINE INSTALLATION

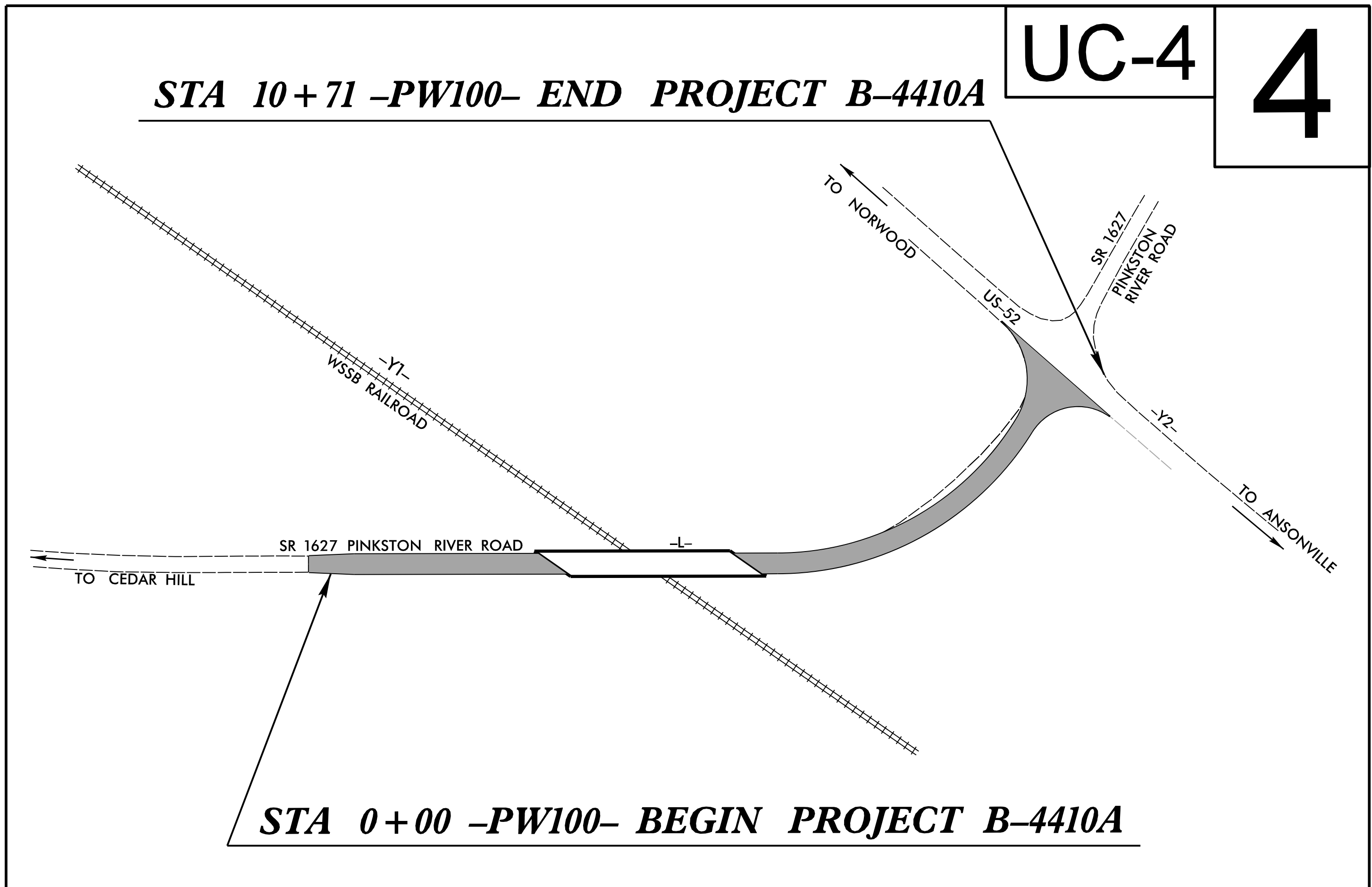
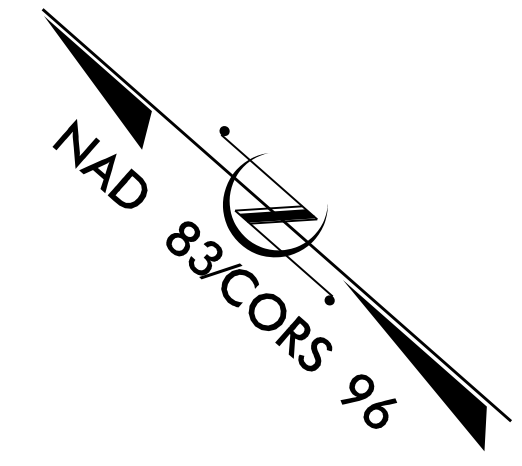

THIS PROJECT IS NOT WITHIN ANY MUNICIPAL BOUNDARIES.

DOCUMENT NOT CONSIDERED FINAL
UNLESS ALL SIGNATURES COMPLETED

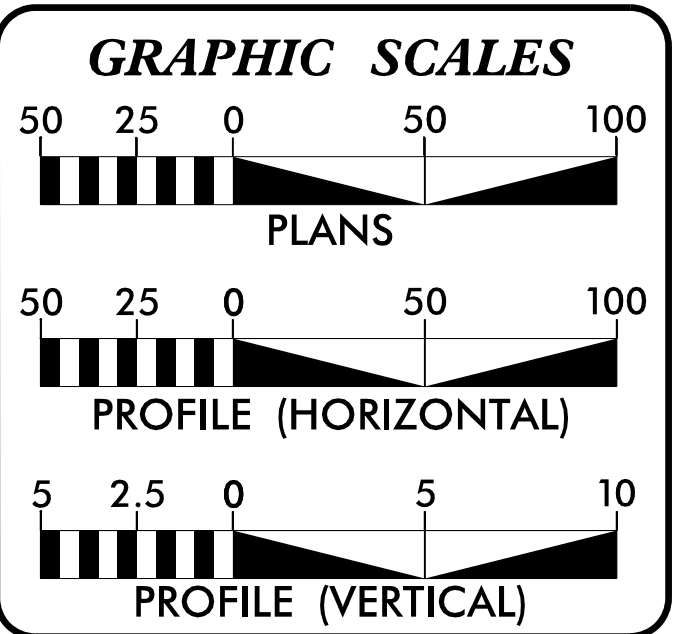

INDEX OF SHEETS

SHEET NO.:	DESCRIPTION:
UC-1	TITLE SHEET
UC-2	UTILITY SYMBOLOGY
UC-3	NOTES
UC-3A	DETAILS
UC-4	UTILITY CONSTRUCTION SHEET
UC-5	PROFILE SHEET

WATER AND SEWER OWNERS ON PROJECT

(A) WATER - TOWN OF ANSONVILLE
(B) SANITARY SEWER - N/A

PREPARED IN THE OFFICE OF

DAVIS • MARTIN • POWELL
ENGINEERS & SURVEYORS **dmp**

6415 OLD PLANK RD., HIGH POINT, NC 27265
PHONE: (336)886-4821 FAX: (336)886-4458
WWW.DMP-INC.COM LICENSE: F-0245

Steve McKee, PE CONSULTANT CONTACT #1
Andy Larrick, PE CONSULTANT CONTACT #2
Ralph Lowe CONSULTANT CONTACT #3

SEAL

**DIVISION OF HIGHWAYS
DIVISION 10**
716 WEST MAIN STREET
ALBEMARLE, NC 28001
PHONE (704) 983-4400
FAX (704) 982-3146











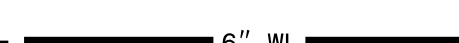

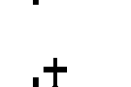
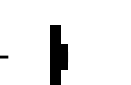



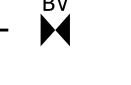
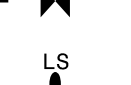
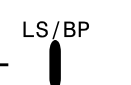
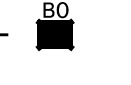

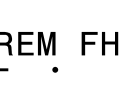

DONALD HARWARD, PLS SENIOR ASST. DIVISION DESIGN CONSTRUCT ENGINEER
JARED MATHIS, PE DESIGN CONSTRUCT ENGINEER

\$\$\$\$\$ SYSTEM \$\$\$\$\$\$
\$\$\$\$\$ DGN \$\$\$\$\$\$
\$\$\$\$\$ USER NAME \$\$\$\$\$\$

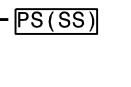

STATE OF NORTH CAROLINA DIVISION OF HIGHWAYS

UTILITIES PLAN SHEET SYMBOLS





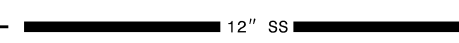
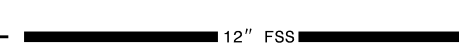

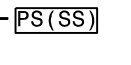
PROPOSED WATER SYMBOLS





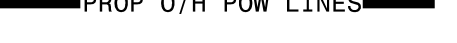
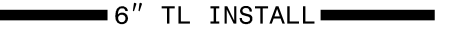
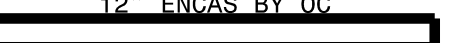

Water Line (Sized as Shown)	
11¼ Degree Bend	
22½ Degree Bend	
45 Degree Bend	
90 Degree Bend	
Plug	
Tee	
Cross	
Reducer	
Gate Valve	
Butterfly Valve	
Tapping Valve	
Line Stop	
Line Stop with Bypass	
Blow Off	
Fire Hydrant	
Relocate Fire Hydrant	
Remove Fire Hydrant	
Water Meter	
Relocate Water Meter	
Remove Water Meter	
Water Pump Station	
RPZ Backflow Preventer	
DCV Backflow Preventer	
Relocate RPZ Backflow Preventer	
Relocate DCV Backflow Preventer	

PROPOSED SEWER SYMBOLS















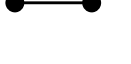



Gravity Sewer Line (Sized as Shown)	
Force Main Sewer Line (Sized as Shown)	
Manhole (Sized per Note)	
Sewer Pump Station	



















PROPOSED MISCELLANEOUS UTILITIES SYMBOLS

Power Pole	
Telephone Pole	
Joint Use Pole	
Telephone Pedestal	
Utility Line by Others (Type as Shown)	
Trenchless Installation	
Encasement by Open Cut	
Encasement	

Thrust Block	
Air Release Valve	
Utility Vault	
Concrete Pier	
Steel Pier	
Plan Note	
Pay Item Note	

EXISTING UTILITIES SYMBOLS

Power Pole	
Telephone Pole	
Joint Use Pole	
Utility Pole	
Utility Pole with Base	
H-Frame Pole	
Power Transmission Line Tower	
Water Manhole	
Power Manhole	
Telephone Manhole	
Sanitary Sewer Manhole	
Hand Hole for Cable	
Power Transformer	
Telephone Pedestal	
CATV Pedestal	
Gas Valve	
Gas Meter	
Located Miscellaneous Utility Object	
Abandoned According to Utility Records	
End of Information	

*Underground Power Line	
*Underground Telephone Cable	
*Underground Telephone Conduit	
*Underground Fiber Optics Telephone Cable	
*Underground TV Cable	
*Underground Fiber Optics TV Cable	
*Underground Gas Pipeline	
Aboveground Gas Pipeline	
*Underground Water Line	
Aboveground Water Line	
*Underground Gravity Sanitary Sewer Line	
Aboveground Gravity Sanitary Sewer Line	
*Underground SS Forced Main Line	
Underground Unknown Utility Line	
SUE Test Hole	
Water Meter	
Water Valve	
Fire Hydrant	
Sanitary Sewer Cleanout	

*For Existing Utilities
 Utility Line Drawn from Record _____
 (Type as Shown)
 Designated Utility Line _____
 (Type as Shown)

5/14/99
 44 43 42 41 40 39 38 37 36 35 34 33 32 31 30 29 28 27 26 25 24 23 22 21 20 19 18 17 16 15 14 13 12 11 10 9 8 7 6 5 4 3 2 1

5/14/99

UTILITY CONSTRUCTION

GENERAL NOTES:

1. THE PROPOSED UTILITY CONSTRUCTION SHALL MEET THE APPLICABLE REQUIREMENTS OF THE NC DEPARTMENT OF TRANSPORTATION'S "STANDARD SPECIFICATIONS FOR ROADS AND STRUCTURES" DATED JANUARY 2018.
2. THE EXISTING WATER UTILITY BELONGS TO THE TOWN OF ANSONVILLE.
3. ALL WATER LINES TO BE INSTALLED WITHIN COMPLIANCE OF THE RULES AND REGULATIONS OF THE NORTH CAROLINA DEPARTMENT OF ENVIRONMENTAL QUALITY, DIVISION OF WATER RESOURCES, PUBLIC WATER SUPPLY SECTION. ALL SEWER LINES TO BE INSTALLED WITHIN COMPLIANCE OF THE RULES AND REGULATIONS OF THE NORTH CAROLINA DEPARTMENT OF ENVIRONMENTAL QUALITY, DIVISION OF WATER RESOURCES, WATER QUALITY SECTION. PERFORM ALL WORK IN ACCORDANCE WITH THE APPLICABLE PLUMBING CODES.
4. THE UTILITY OWNER OWNS THE EXISTING UTILITY FACILITIES AND WILL OWN THE NEW UTILITY FACILITIES AFTER ACCEPTANCE BY THE DEPARTMENT. THE DEPARTMENT OWNS THE CONSTRUCTION CONTRACT AND HAS ADMINISTRATIVE AUTHORITY. COMMUNICATIONS AND DECISIONS BETWEEN THE CONTRACTOR AND UTILITY OWNER ARE NOT BINDING UPON THE DEPARTMENT OR THIS CONTRACT UNLESS AUTHORIZED BY THE ENGINEER. AGREEMENTS BETWEEN THE UTILITY OWNER AND CONTRACTOR FOR THE WORK THAT IS NOT PART OF THIS CONTRACT OR IS SECONDARY TO THIS CONTRACT ARE ALLOWED, BUT ARE NOT BINDING UPON THE DEPARTMENT.
5. PROVIDE ACCESS FOR THE DEPARTMENT PERSONNEL AND THE OWNER'S REPRESENTATIVES TO ALL PHASES OF CONSTRUCTION. NOTIFY DEPARTMENT PERSONNEL AND THE UTILITY OWNER TWO WEEKS PRIOR TO COMMENCEMENT OF ANY WORK AND ONE WEEK PRIOR TO SERVICE INTERRUPTION. KEEP UTILITY OWNERS' REPRESENTATIVES INFORMED OF WORK PROGRESS AND PROVIDE OPPORTUNITY FOR INSPECTION OF CONSTRUCTION AND TESTING.

6. THE PLANS DEPICT THE BEST AVAILABLE INFORMATION FOR THE LOCATION, SIZE, AND TYPE OF MATERIAL FOR ALL EXISTING UTILITIES. MAKE INVESTIGATIONS FOR DETERMINING THE EXACT LOCATION, SIZE, AND TYPE MATERIAL OF THE EXISTING FACILITIES AS NECESSARY FOR THE CONSTRUCTION OF THE PROPOSED UTILITIES AND FOR AVOIDING DAMAGE TO EXISTING FACILITIES. REPAIR ANY DAMAGE INCURRED TO EXISTING FACILITIES TO THE ORIGINAL OR BETTER CONDITION AT NO ADDITIONAL COST TO THE DEPARTMENT.
7. MAKE FINAL CONNECTIONS OF THE NEW WORK TO THE EXISTING SYSTEM WHERE INDICATED ON THE PLANS, AS REQUIRED TO FIT THE ACTUAL CONDITIONS, OR AS DIRECTED.
8. MAKE CONNECTIONS BETWEEN EXISTING AND PROPOSED UTILITIES AT TIMES MOST CONVENIENT TO THE PUBLIC, WITHOUT ENDANGERING THE UTILITY SERVICE, AND IN ACCORDANCE WITH THE UTILITY OWNER'S REQUIREMENTS. MAKE CONNECTIONS ON WEEKENDS, AT NIGHT, AND ON HOLIDAYS IF NECESSARY.
9. ALL UTILITY MATERIALS SHALL BE APPROVED PRIOR TO DELIVERY TO THE PROJECT. SEE 1500-7, " SUBMITTALS AND RECORDS" IN SECTION 1500 OF THE STANDARD SPECIFICATIONS.

PROJECT SPECIFIC NOTES:

1. UNLESS OTHERWISE NOTED, PROPOSED WATER MAINS 4" AND LARGER SHALL BE C900 PVC.
2. USE 6" D.I. PIPE, PC 350 AND 6" D.I. RESTRAINED JOINT PIPE, PC 350 FOR PROPOSED WATER MAINS WHERE NOTED ON THE PROFILE ON SHEET UC-5.
3. WATER LINE VALVES SHALL BE RESILIENT-SEAT GATE VALVES, CONFORMING TO ANSI/AWWA C509 OR ANSI/AWWA C515, AND SHALL BE RATED FOR A MINIMUM WORKING PRESSURE OF 250 PSI.

LIST OF STANDARD DRAWINGS

- 1515.01 WATER METER
- 1515.02 FIRE HYDRANT

PROJECT REFERENCE NO.	SHEET NO.
B-4410A	UC-3
DESIGNED BY: JSM	
DRAWN BY: RDL	
CHECKED BY: APL	
APPROVED BY:	
REVISED:	
NORTH CAROLINA DEPARTMENT OF TRANSPORTATION	UTILTY CONSTRUCTION PLANS ONLY
UTILITIES ENGINEERING SEC. PHONE: (919) 707-6690 FAX: (919) 250-4151	

UTILITY CONSTRUCTION

DOCUMENT NOT CONSIDERED FINAL UNLESS ALL SIGNATURES COMPLETED

5/14/2022

PROJECT TYPICAL DETAILS

PROJECT REFERENCE NO.	SHEET NO.
B-4410A	UC-3A
DESIGNED BY: JSM	
DRAWN BY: RDL	
CHECKED BY: APL	
APPROVED BY:	
REVISED:	
NORTH CAROLINA DEPARTMENT OF TRANSPORTATION	
UTILITIES ENGINEERING SEC. PHONE: (919) 707-6690 FAX: (919) 250-4151	7/13/2022 UTILITY CONSTRUCTION PLANS ONLY

UTILITY CONSTRUCTION

DOCUMENT NOT CONSIDERED FINAL UNLESS ALL SIGNATURES COMPLETED

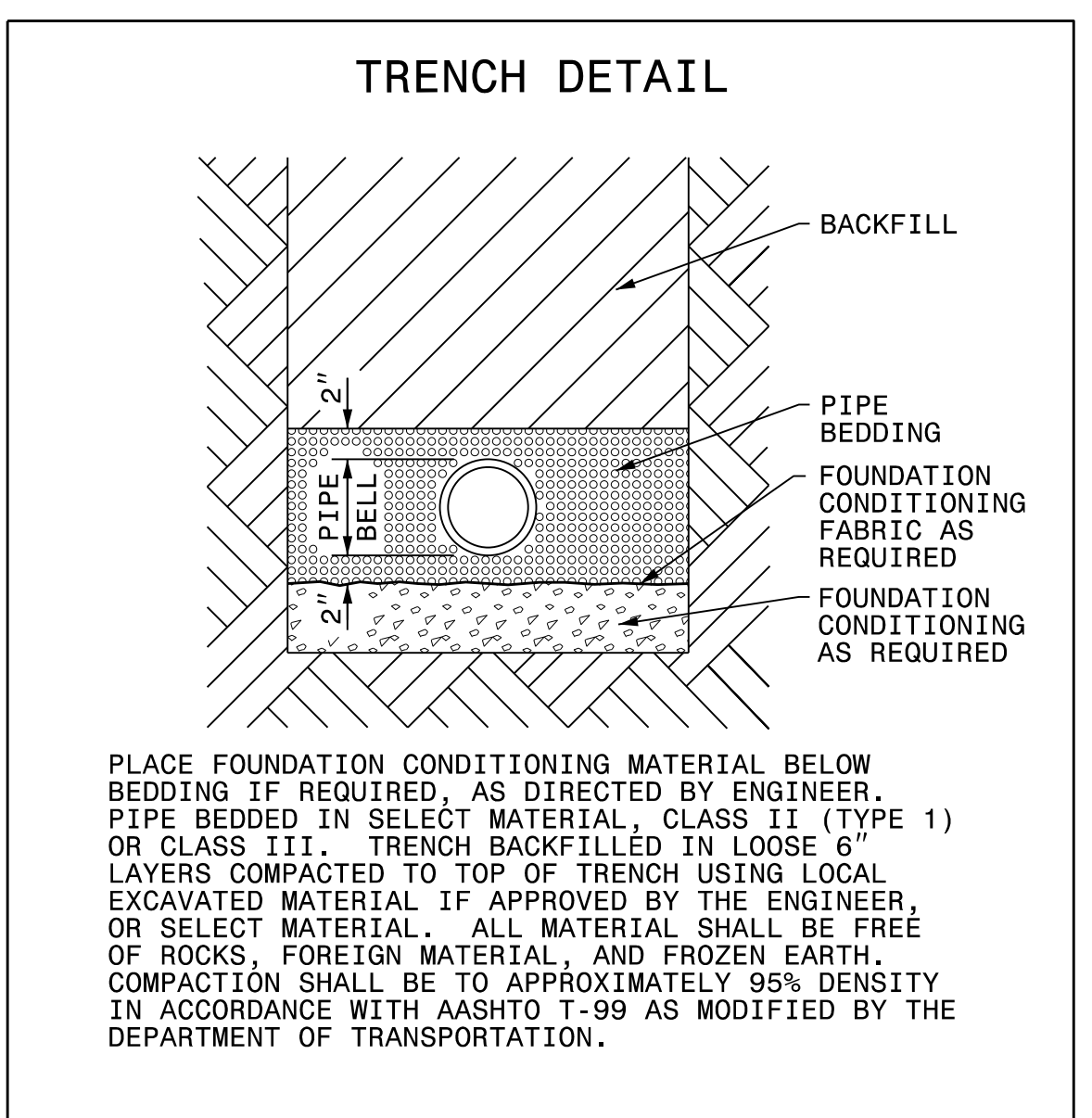
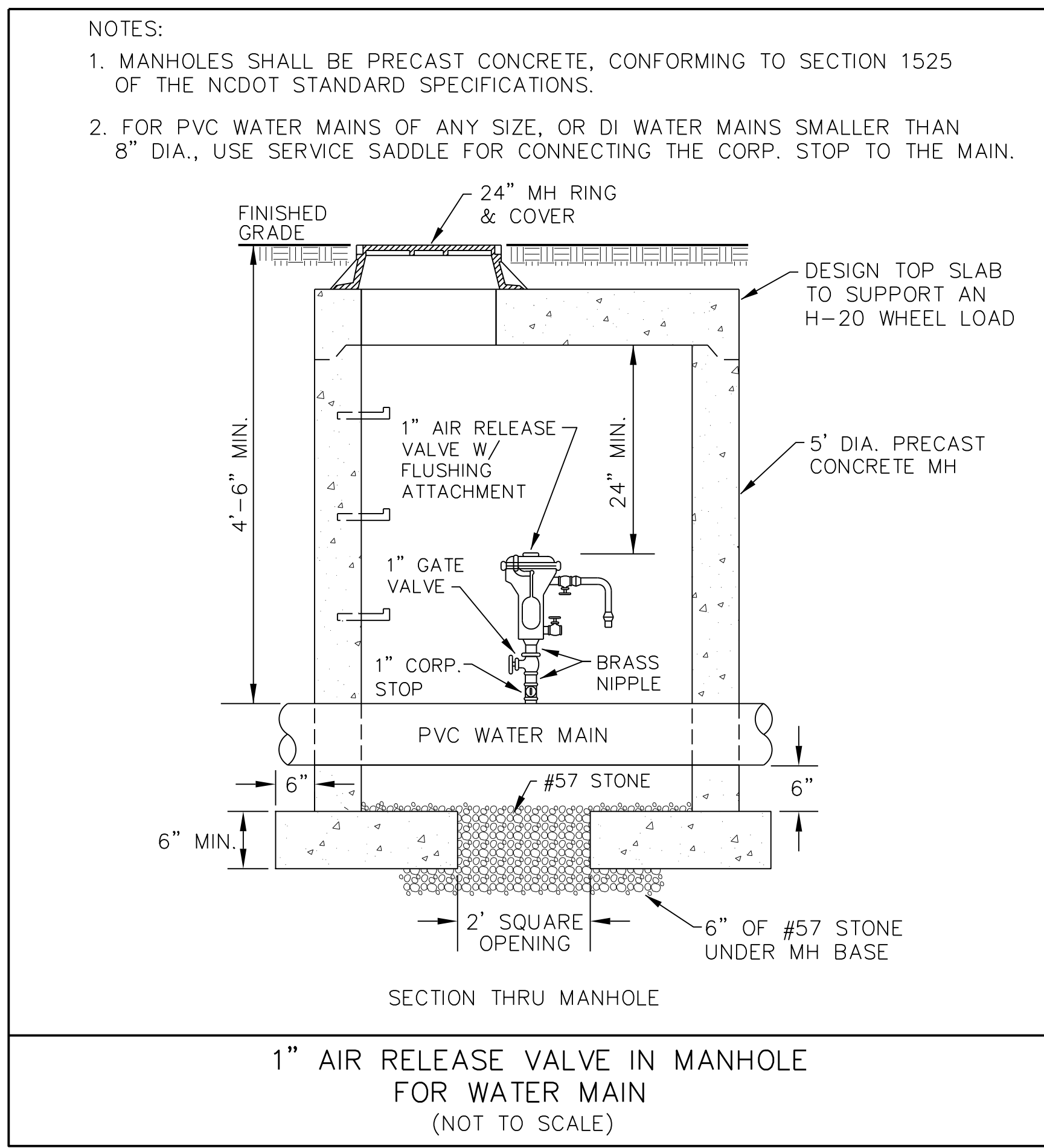
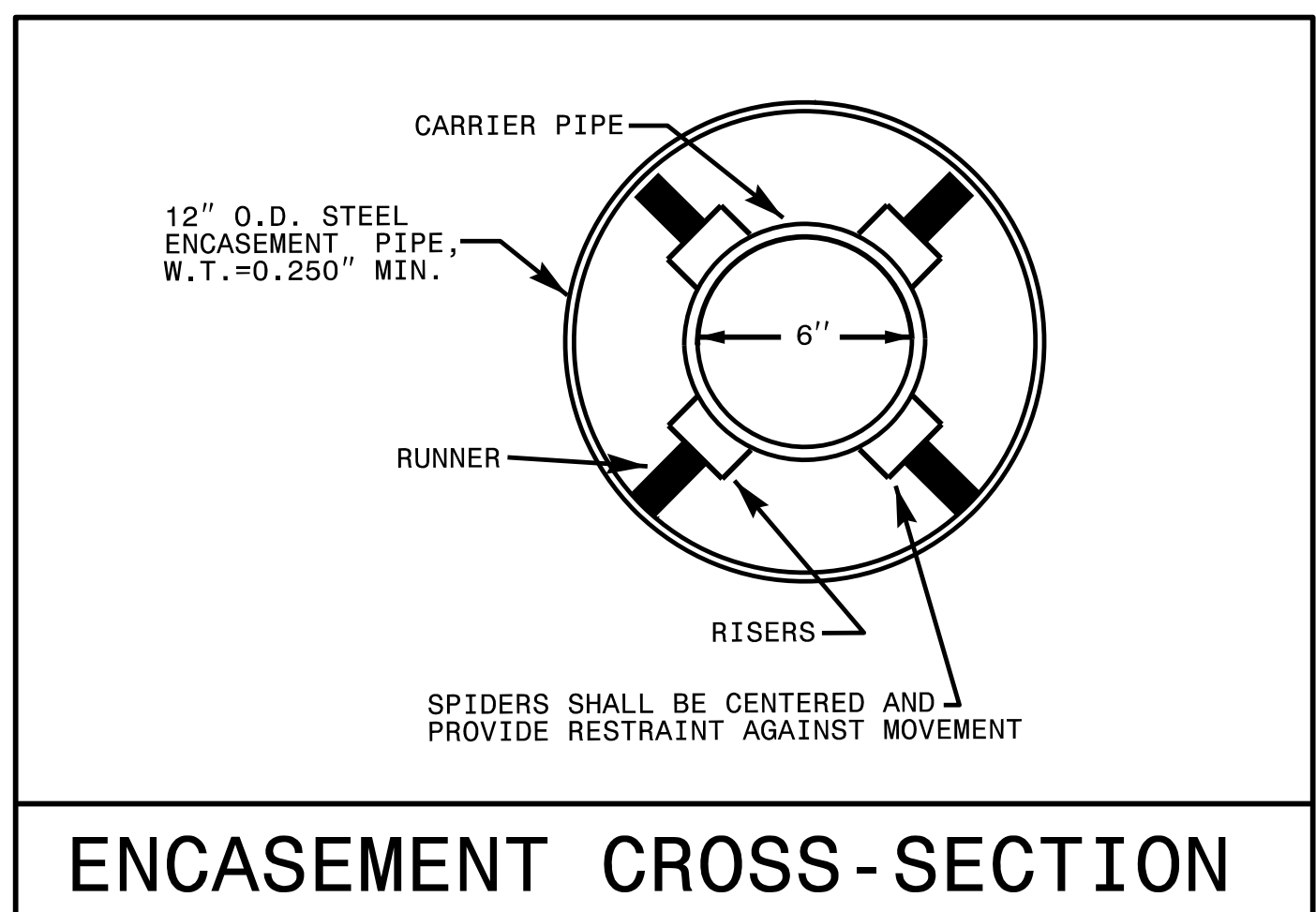
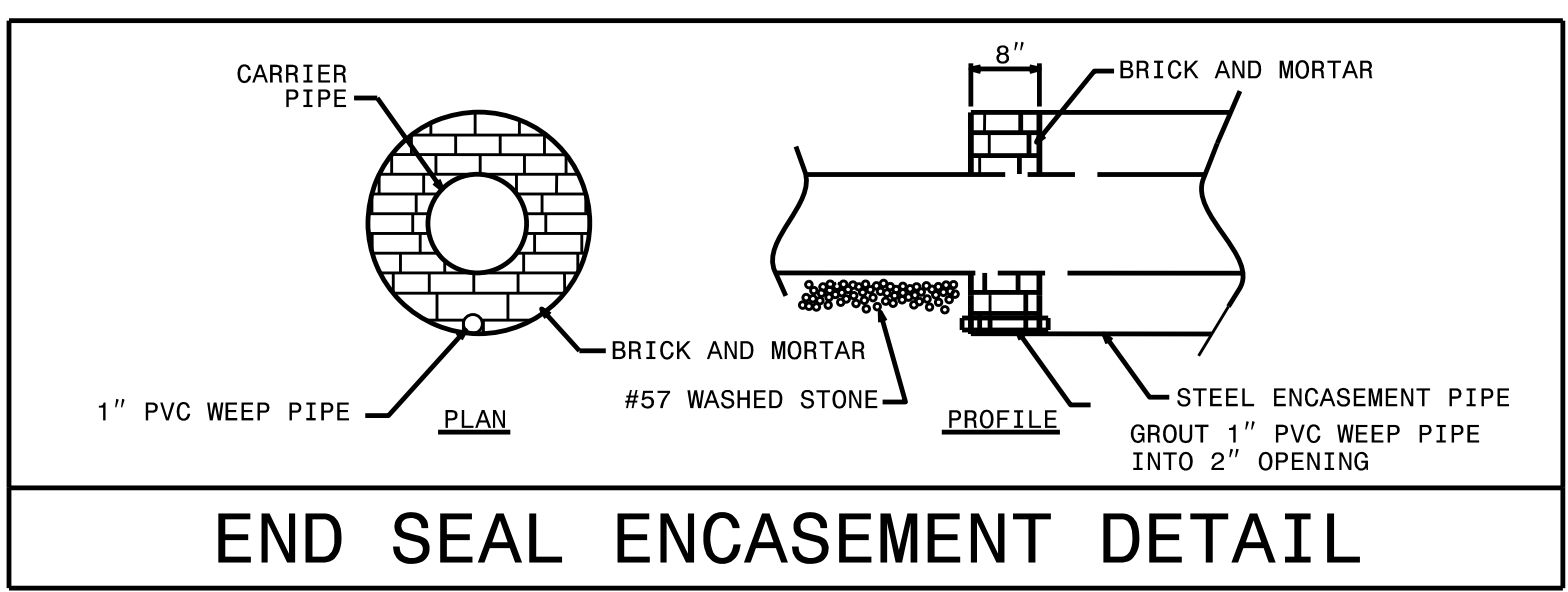
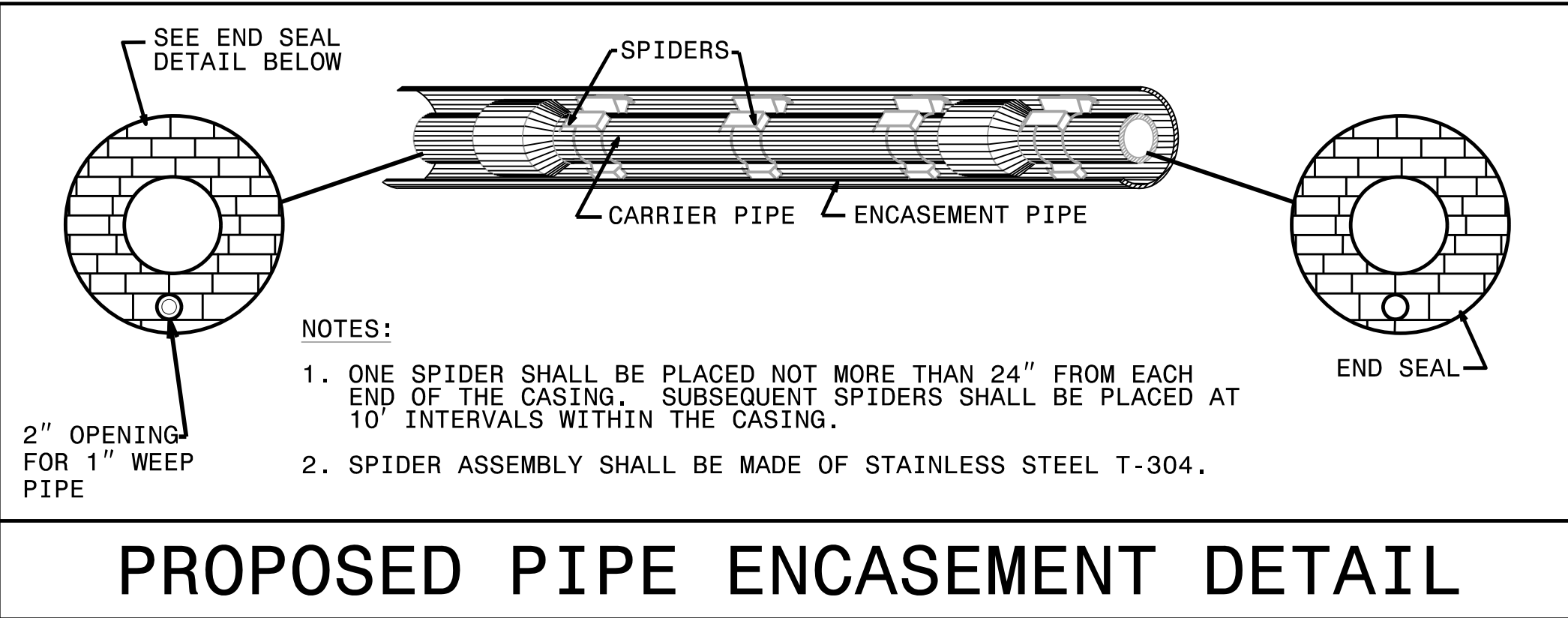

MAXIMUM TRENCH WIDTH AT TOP OF PIPE

NOMINAL PIPE SIZE (INCHES)	TRENCH WIDTH (INCHES)	NOMINAL PIPE SIZE (INCHES)	TRENCH WIDTH (INCHES)
4	28	20	44
6	30	24	48
8	32	30	54
10	34	36	60
12	36	42	66
14	38	48	72
16	40	54	78
18	42		

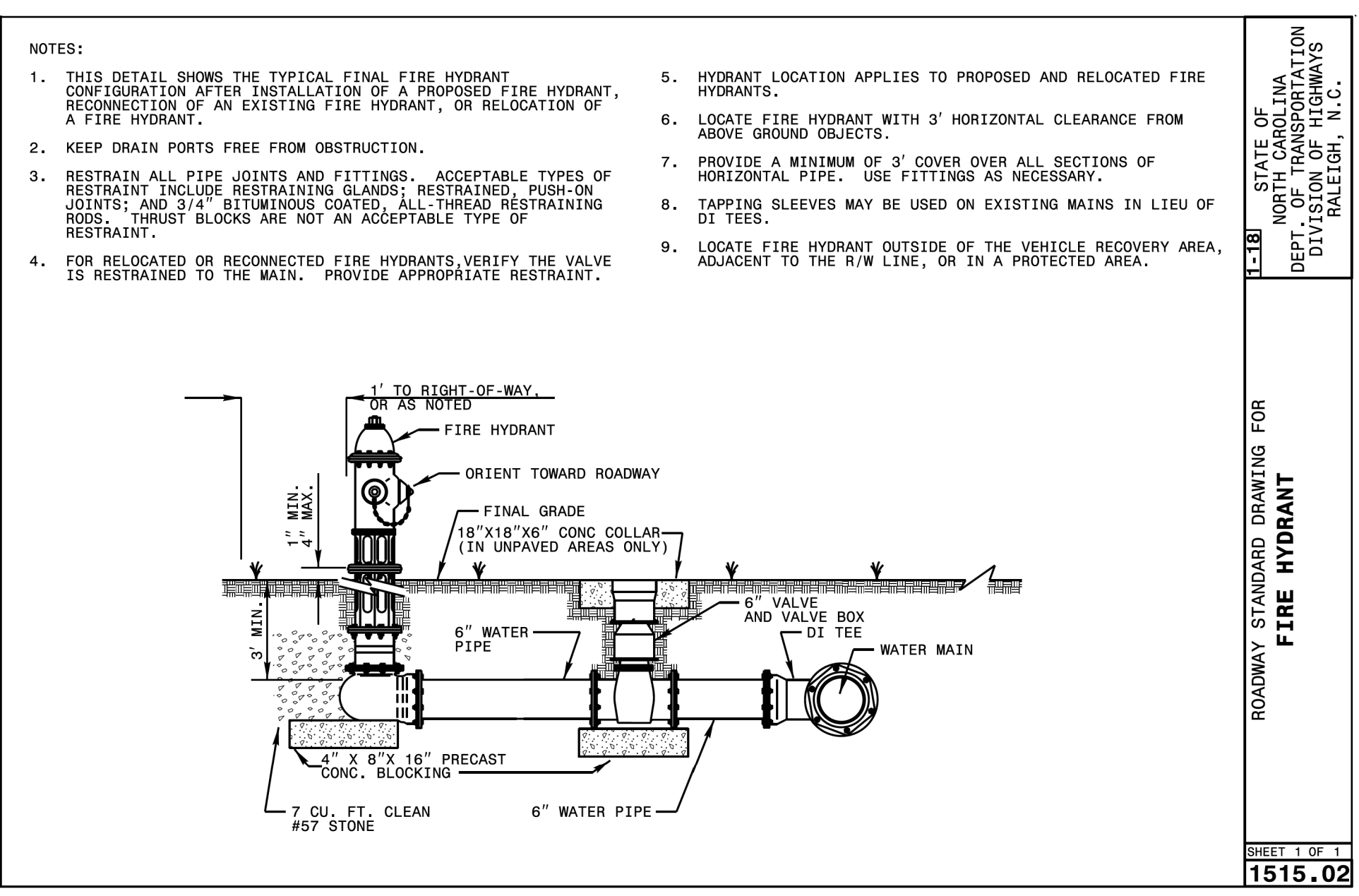
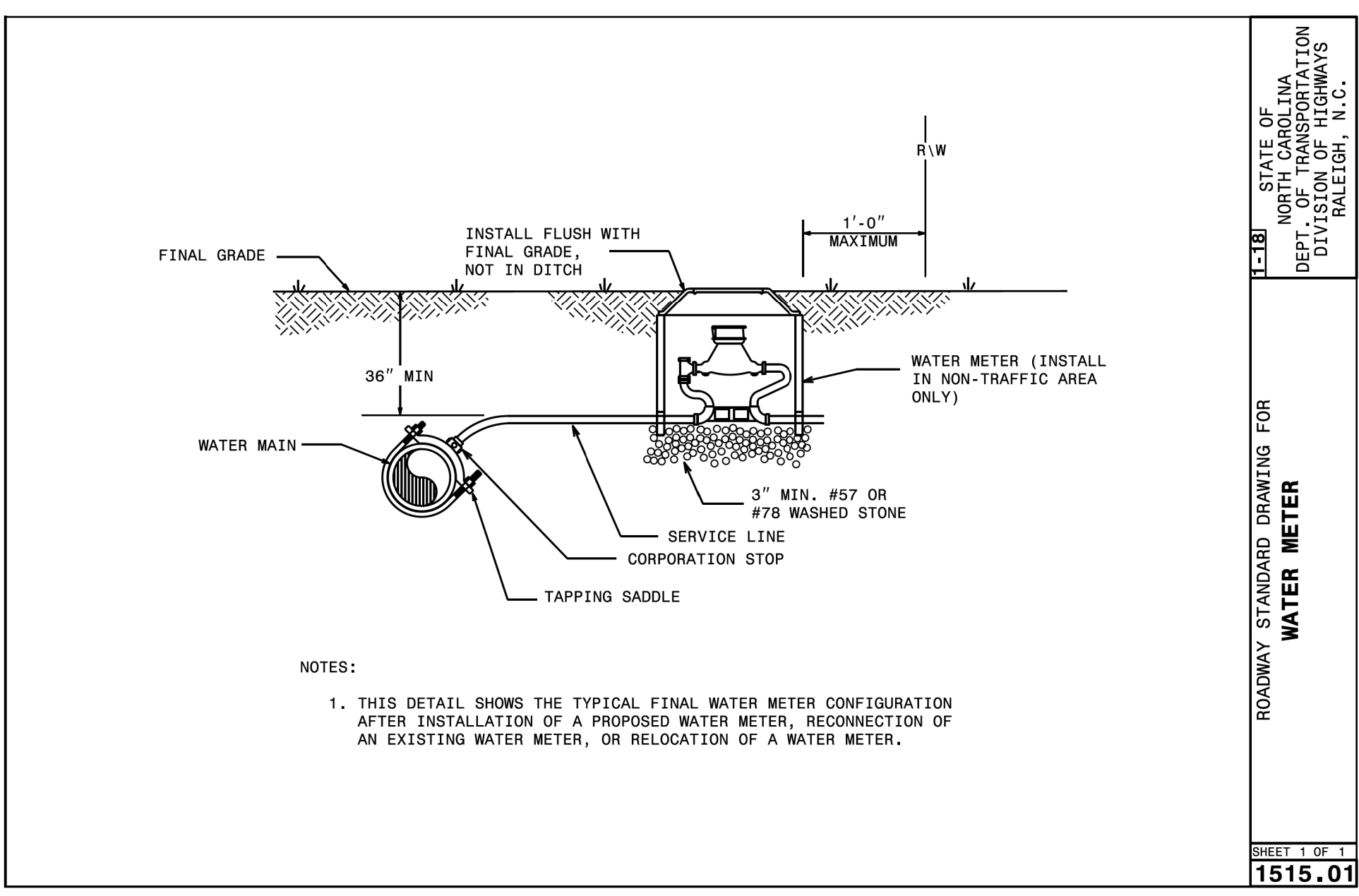

PROJECT REFERENCE NO. B-4410A	SHEET NO. UC-4
DESIGNED BY: JSM	
DRAWN BY: RDL	
CHECKED BY: APL	
APPROVED BY:	
REVISED:	
NORTH CAROLINA DEPARTMENT OF TRANSPORTATION	7/13/2022
UTILITIES ENGINEERING SEC. PHONE: (919) 707-6690 FAX: (919) 250-4151	UTILITY CONSTRUCTION PLANS ONLY

UTILITY CONSTRUCTION

DOCUMENT NOT CONSIDERED FINAL UNLESS ALL SIGNATURES COMPLETED

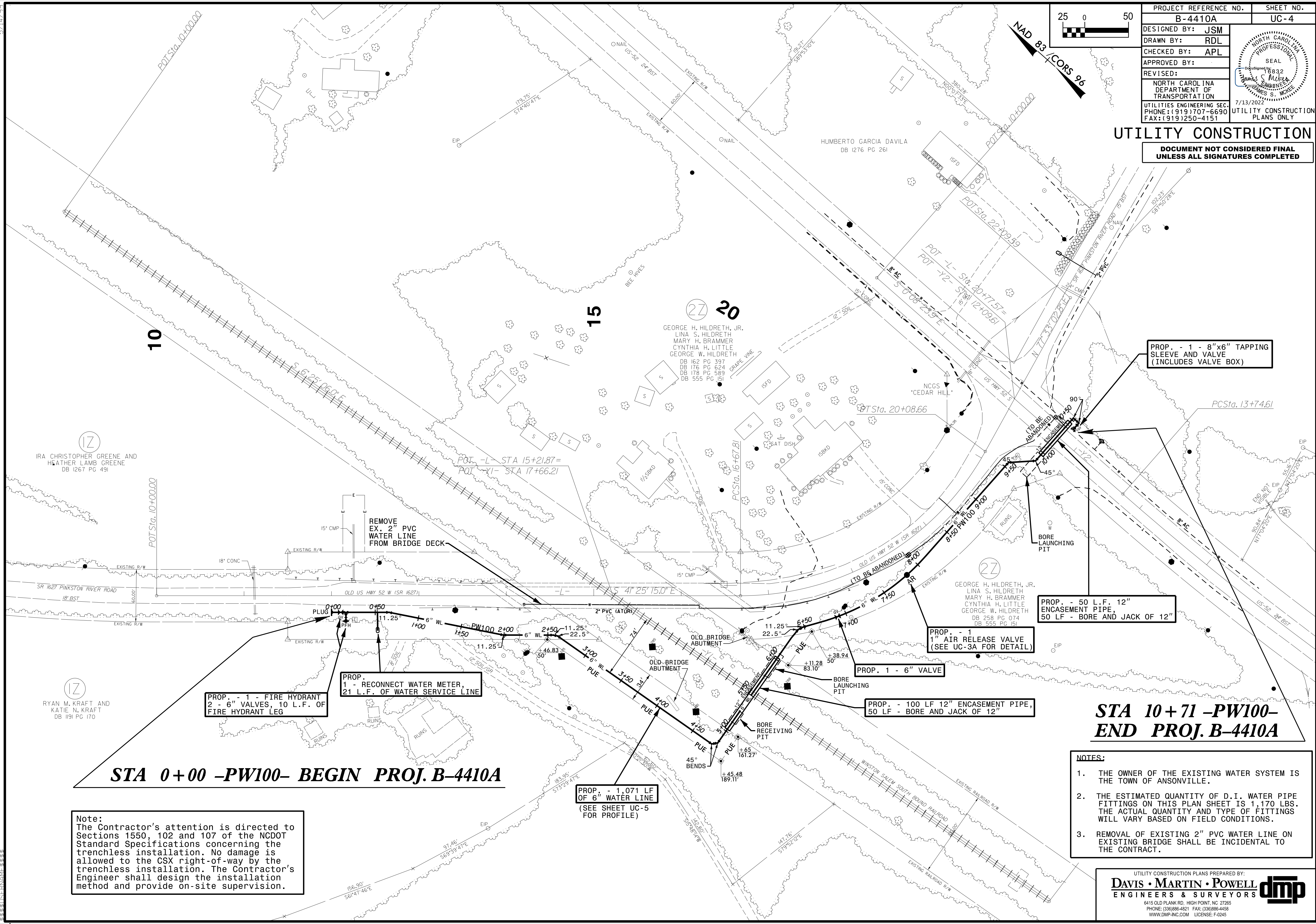

Note:
The Contractor's attention is directed to Sections 1550, 102 and 107 of the NCDOT Standard Specifications concerning the trenchless installation. No damage is allowed to the CSX right-of-way by the trenchless installation. The Contractor's Engineer shall design the installation method and provide on-site supervision.

- NOTES:**
1. THE OWNER OF THE EXISTING WATER SYSTEM IS THE TOWN OF ANSONVILLE.
 2. THE ESTIMATED QUANTITY OF D.I. WATER PIPE FITTINGS ON THIS PLAN SHEET IS 1,170 LBS. THE ACTUAL QUANTITY AND TYPE OF FITTINGS WILL VARY BASED ON FIELD CONDITIONS.
 3. REMOVAL OF EXISTING 2" PVC WATER LINE ON EXISTING BRIDGE SHALL BE INCIDENTAL TO THE CONTRACT.

STA 10+71 -PW100- END PROJ. B-4410A

TIP PROJECT: B-4410A

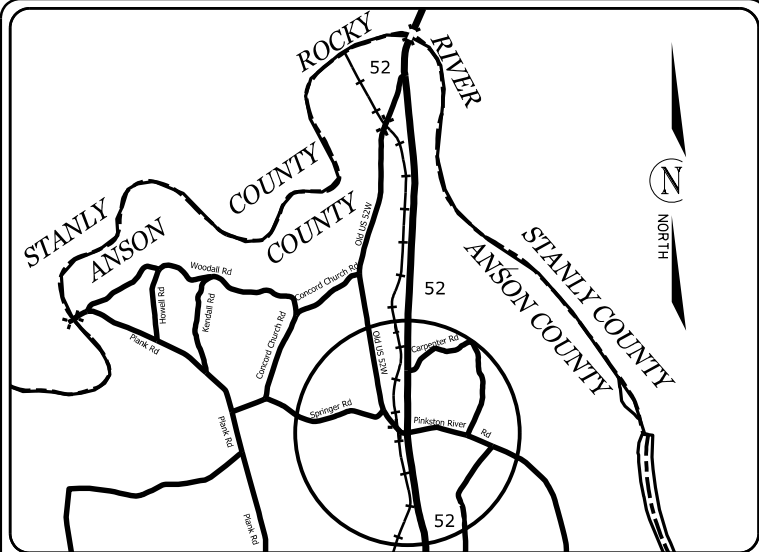

VICINITY MAP
NOT TO SCALE

STATE OF NORTH CAROLINA
DIVISION OF HIGHWAYS
**PLAN FOR PROPOSED
HIGHWAY EROSION CONTROL
ANSON COUNTY**

**LOCATION: INTERSECTION OF US HIGHWAY 52S
AND OLD US HIGHWAY 52W (SR-1627)**

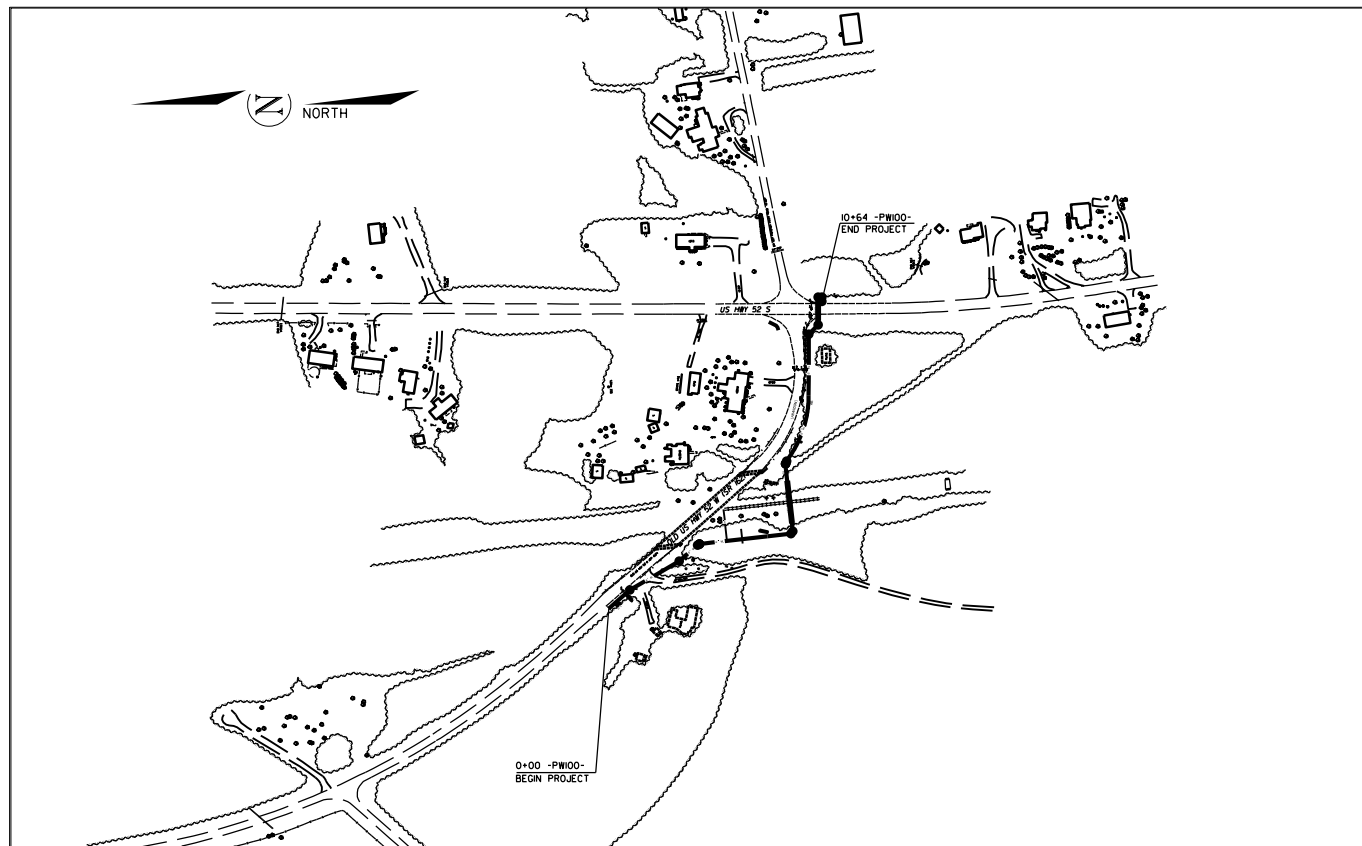

INSTALL PERIMETER EROSION CONTROL MEASURES DURING INITIAL CLEARING PHASE

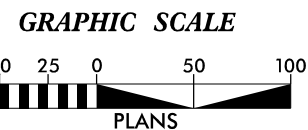

THESE EROSION AND SEDIMENT CONTROL PLANS COMPLY WITH THE APPLICABLE REGULATIONS SET FORTH BY THE NCG-010000 GENERAL CONSTRUCTION PERMIT EFFECTIVE APRIL 1, 2019 AND ISSUED BY THE NORTH CAROLINA DEPARTMENT OF ENVIRONMENTAL QUALITY DIVISION OF WATER RESOURCES.



Prepared In the Office of:
DDC UNIT DIVISION 10
DEPARTMENT OF TRANSPORTATION
DIVISION OF HIGHWAYS

Designed by:
JASON BROOKS **4369**
NAME LEVEL III CERTIFICATION NO.

Roadway Standard Drawings

The following roadway english standards as appear in "Roadway Standard Drawings"- Roadway Design Unit - N. C. Department of Transportation - Raleigh, N. C., dated January 2018 and the latest revision thereto are applicable to this project and by reference hereby are considered a part of these plans.

1604.01 Railroad Erosion Control Detail	1632.01 Rock Inlet Sediment Trap Type A
1605.01 Temporary Silt Fence	1632.02 Rock Inlet Sediment Trap Type B
1606.01 Special Sediment Control Fence	1632.03 Rock Inlet Sediment Trap Type C
1607.01 Gravel Construction Entrance	1633.01 Temporary Rock Silt Check Type A
1622.01 Temporary Berms and Slope Drains	1633.02 Temporary Rock Silt Check Type B
1630.01 Riser Basin	1633.03 Temporary Rock Silt Check Type C
1630.02 Silt Basin Type 1	1634.01 Temporary Rock Sediment Dam Type A
1630.03 Temporary Silt Ditch	1634.02 Temporary Rock Sediment Dam Type B
1630.04 Stilling Basin	1635.01 Rock Pipe Inlet Sediment Trap Type A
1630.05 Temporary Diversion	1635.02 Rock Pipe Inlet Sediment Trap Type B
1630.06 Special Stilling Basin	1640.01 Coir Fiber Jaffle
1631.01 Matting Installation	1645.01 Temporary Stream Crossing

STATE	STATE PROJECT REFERENCE NO.	SHEET NO.	TOTAL SHEETS
N.C.	B-4410A	EC-1	
STATE PROJ. NO.	F.A. PROJ. NO.	DESCRIPTION	
33688.1.2		P.E.	
33688.2.2		R/W	
33688.3.2		CONST.	

EROSION AND SEDIMENT CONTROL MEASURES

Sid. #	Description	Symbol
1630.03	Temporary Silt Ditch	TD
1630.05	Temporary Diversion	TD
1605.01	Temporary Silt Fence	
1606.01	Special Sediment Control Fence	▲▲▲
1622.01	Temporary Berms and Slope Drains	▲
1630.02	Silt Basin Type B	▨
1633.01	Temporary Rock Silt Check Type-A	▩
	Temporary Rock Silt Check Type-A with Matting and Polyacrylamide (PAM)	▩
1633.02	Temporary Rock Silt Check Type-B	▶
	Wattle / Coir Fiber Wattle	○
	Wattle / Coir Fiber Wattle with Polyacrylamide (PAM)	○
1634.01	Temporary Rock Sediment Dam Type-A	▩
1634.02	Temporary Rock Sediment Dam Type-B	▩
1635.01	Rock Pipe Inlet Sediment Trap Type-A	⊓
1635.02	Rock Pipe Inlet Sediment Trap Type-B	⊓
1630.04	Stilling Basin	▭
1630.06	Special Stilling Basin	▭
	Rock Inlet Sediment Trap:	
1632.01	Type A	A
1632.02	Type B	B
1632.03	Type C	C
	Skimmer Basin	▭
	Tiered Skimmer Basin	▭
	Infiltration Basin	▭

THIS PROJECT CONTAINS
EROSION CONTROL PLANS
FOR CLEARING AND
GRUBBING PHASE OF
CONSTRUCTION.

WATTLE WITH POLYACRYLAMIDE (PAM) DETAIL

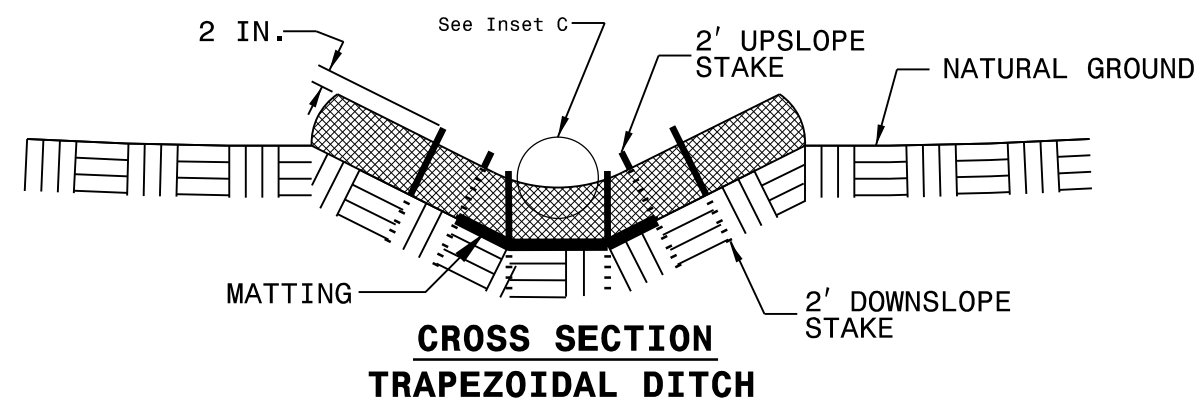
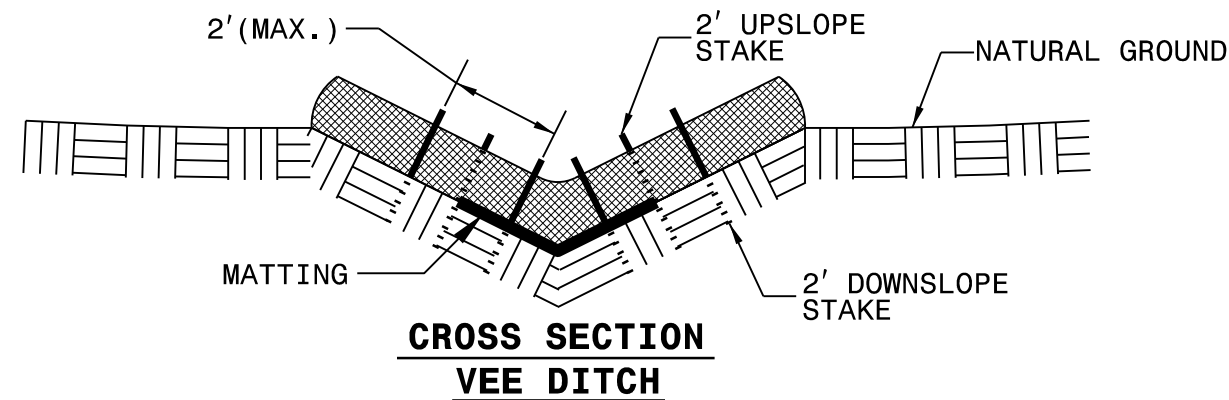
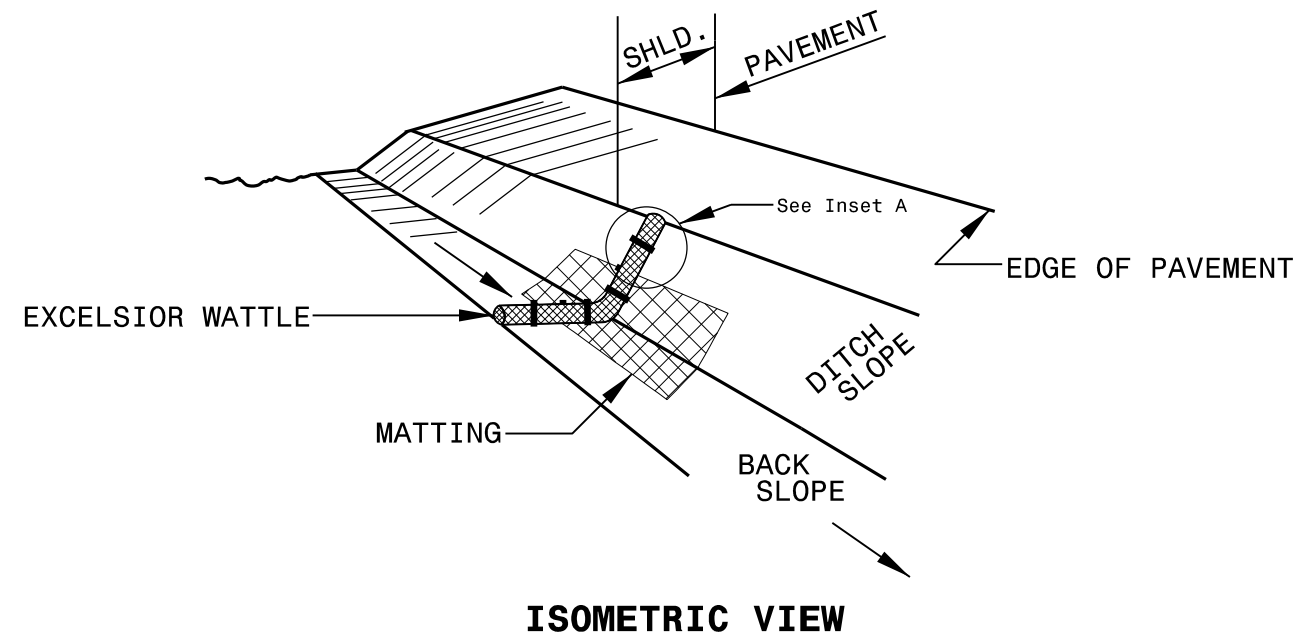

NOTES:

USE MINIMUM 12 IN. DIAMETER EXCELSIOR WATTLE.

USE 2 FT. WOODEN STAKES WITH A 2 IN. BY 2 IN. NOMINAL CROSS SECTION.

ONLY INSTALL WATTLE(S) TO A HEIGHT IN DITCH SO FLOW WILL NOT WASH AROUND WATTLE AND SCOUR DITCH SLOPES AND AS DIRECTED.

INSTALL A MINIMUM OF 2 UPSLOPE STAKES AND 4 DOWNSLOPE STAKES AT AN ANGLE TO WEDGE WATTLE TO BOTTOM OF DITCH.

PROVIDE STAPLES MADE OF 0.125 IN. DIAMETER STEEL WIRE FORMED INTO A U SHAPE NOT LESS THAN 12" IN LENGTH.

INSTALL STAPLES APPROXIMATELY EVERY 1 LINEAR FOOT ON BOTH SIDES OF WATTLE AND AT EACH END TO SECURE IT TO THE SOIL.

INSTALL MATTING IN ACCORDANCE WITH SECTION 1631 OF THE STANDARD SPECIFICATIONS.

PRIOR TO POLYACRYLAMIDE (PAM) APPLICATION, OBTAIN A SOIL SAMPLE FROM PROJECT LOCATION, AND FROM OFFSITE MATERIAL, AND ANALYZE FOR APPROPRIATE PAM FLOCCULANT TO BE APPLIED TO EACH WATTLE.

INITIALLY APPLY 2 OUNCES OF ANIONIC OR NEUTRALLY CHARGED PAM OVER WATTLE WHERE WATER WILL FLOW AND 1 OUNCE OF PAM ON MATTING ON EACH SIDE OF WATTLE. REAPPLY PAM AFTER EVERY RAINFALL EVENT THAT IS EQUAL TO OR EXCEEDS 0.50 IN.

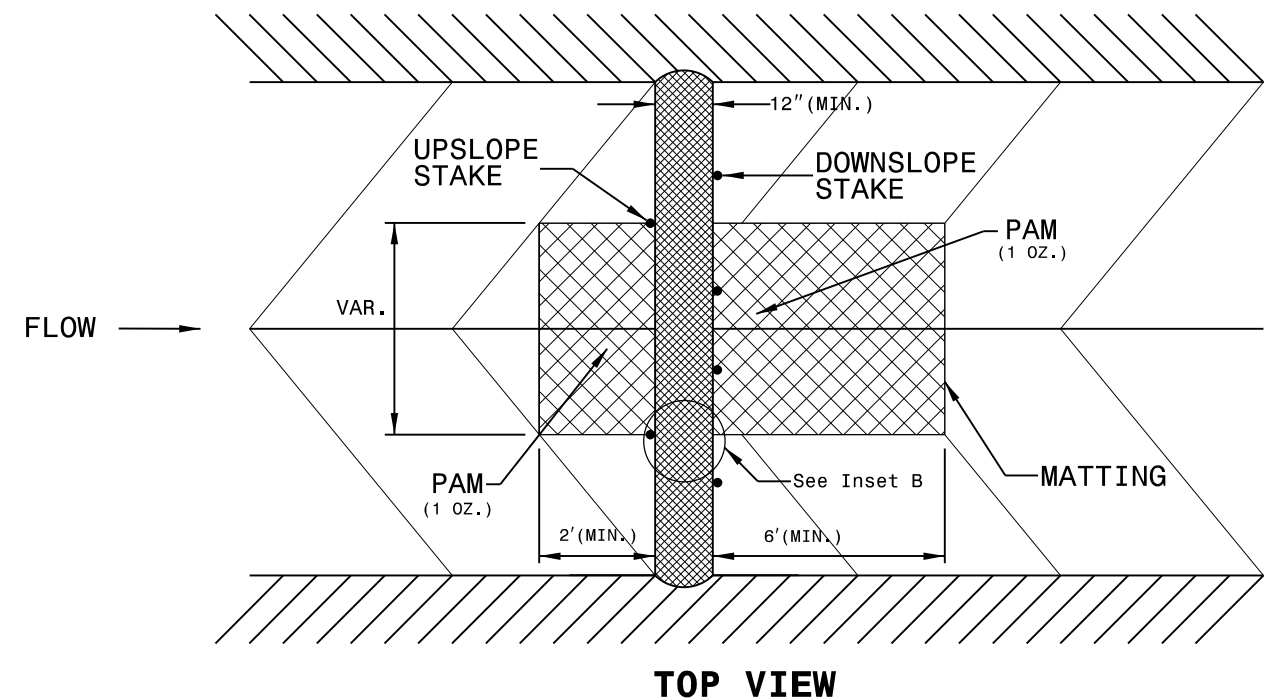
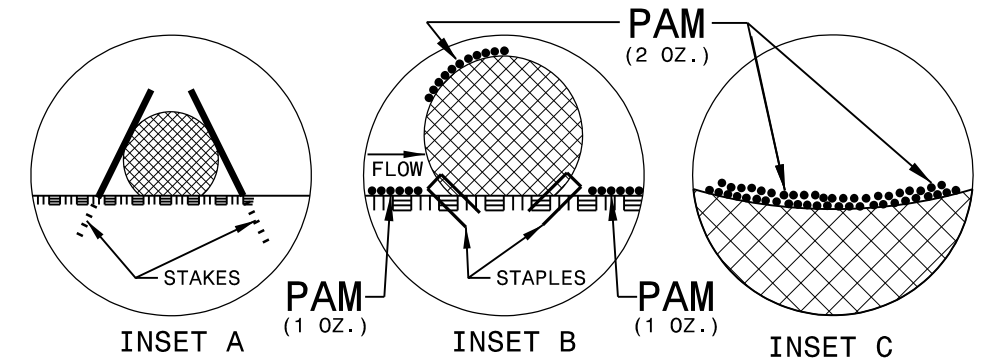

PROJECT REFERENCE NO. 33688.3.2	SHEET NO. EC-2A
RW SHEET NO.	
ROADWAY DESIGN ENGINEER	HYDRAULICS ENGINEER

MATTING INSTALLATION DETAIL

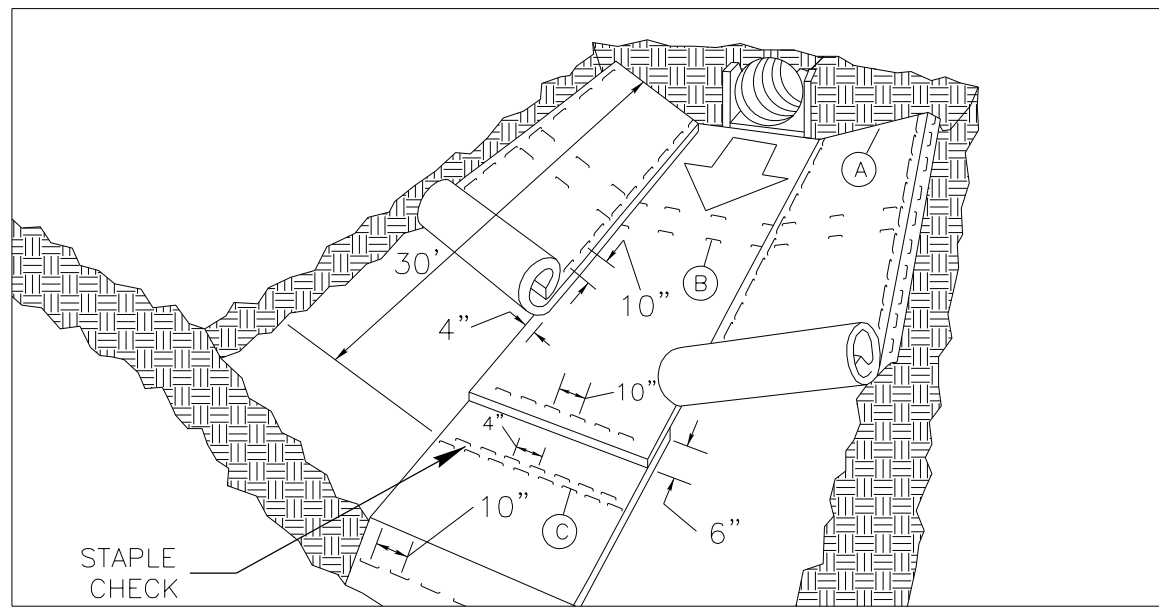

MATTING IN DITCHES

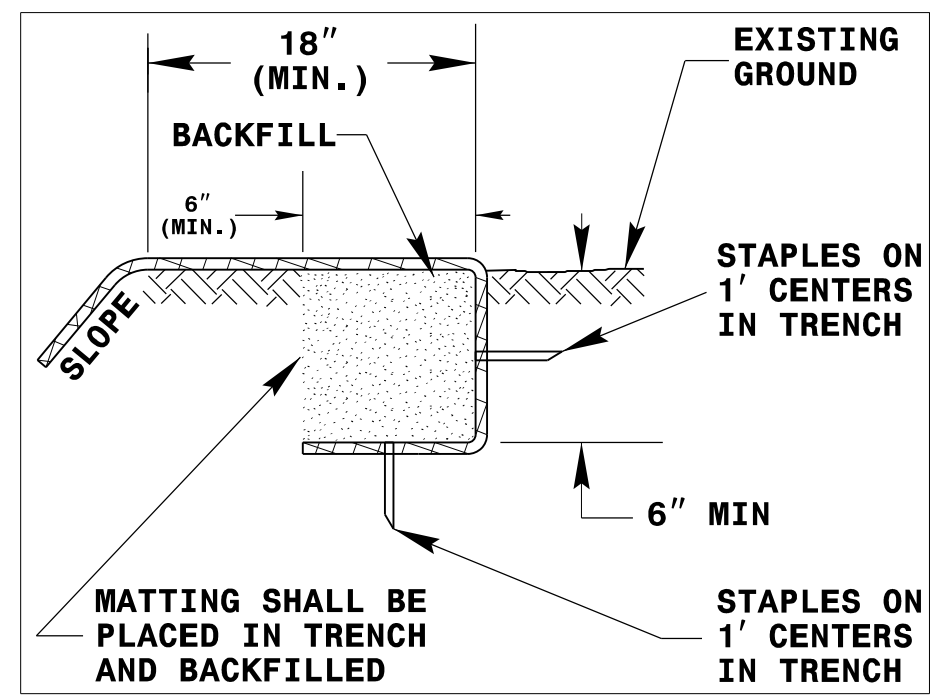
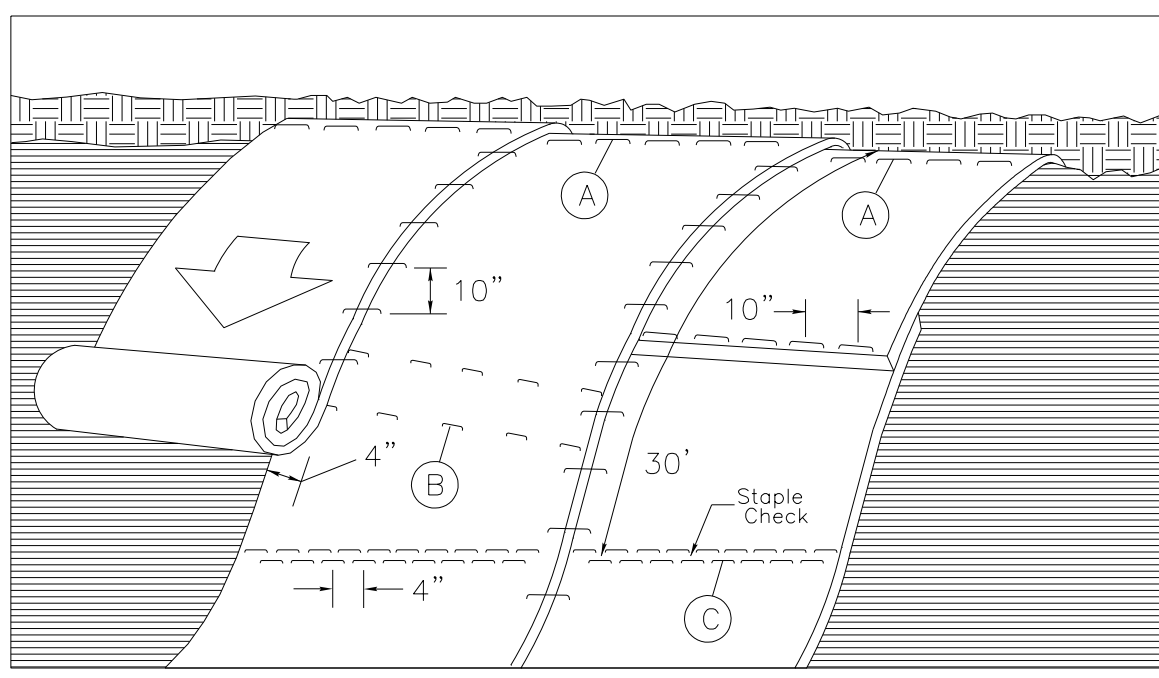

DIAGRAM (A)



MATTING ON SLOPES

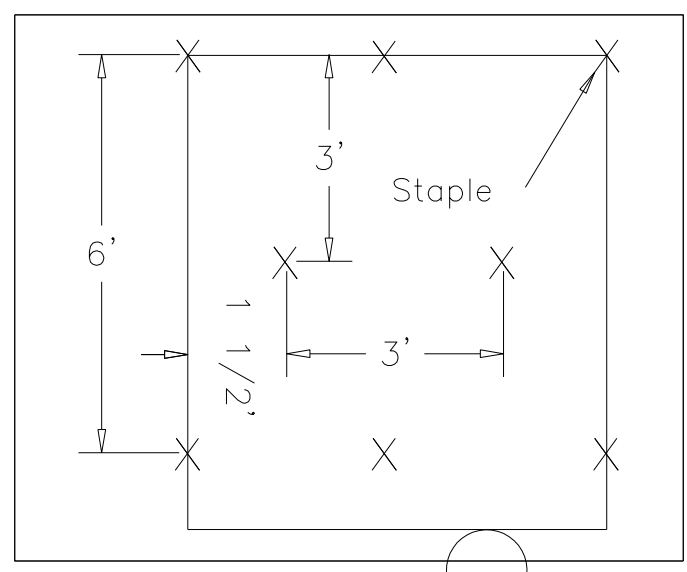

DIAGRAM (B)

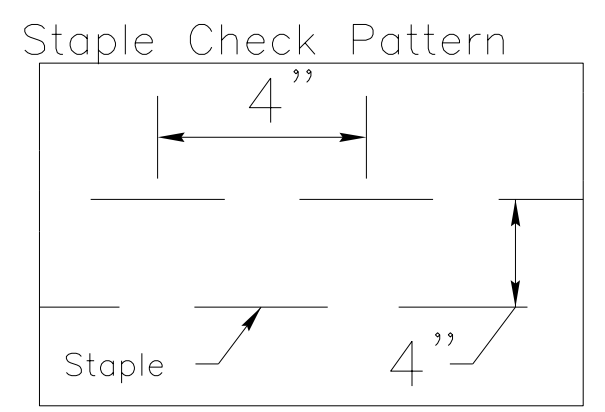

DIAGRAM (C)

NOTES:

THIS DETAIL APPLIES TO STRAW, EXCELSIOR, AND PERMANENT SOIL REINFORCEMENT MAT (PSRM) INSTALLATION.
 STAPLES SHALL BE NO. 11 GAUGE STEEL WIRE FORMED INTO A "U" SHAPE WITH A MINIMUM THROAT WIDTH OF 1 INCH AND NOT LESS THAN 6 INCHES IN LENGTH.

NOT TO SCALE

DIVISION OF HIGHWAYS
STATE OF NORTH CAROLINA

PROJECT REFERENCE NO. 33688.3.2	SHEET NO. EC-3
ROADWAY DESIGN ENGINEER	HYDRAULICS ENGINEER

SOIL STABILIZATION TIMEFRAMES

<i>SITE DESCRIPTION</i>	<i>STABILIZATION TIME</i>	<i>TIMEFRAME EXCEPTIONS</i>
PERIMETER DIKES, SWALES, DITCHES AND SLOPES	7 DAYS	NONE
HIGH QUALITY WATER (HOW) ZONES	7 DAYS	NONE
SLOPES STEEPER THAN 3:1	7 DAYS	IF SLOPES ARE 10' OR LESS IN LENGTH AND ARE NOT STEEPER THAN 2:1, 14 DAYS ARE ALLOWED.
SLOPES 3:1 OR FLATTER	14 DAYS	7 DAYS FOR SLOPES GREATER THAN 50' IN LENGTH.
ALL OTHER AREAS WITH SLOPES FLATTER THAN 4:1	14 DAYS	NONE, EXCEPT FOR PERIMETERS AND HOW ZONES.

PROJECT NO.	SHEET NO.
33688.3.2	EC-4
F.A. PROJECT NO.	

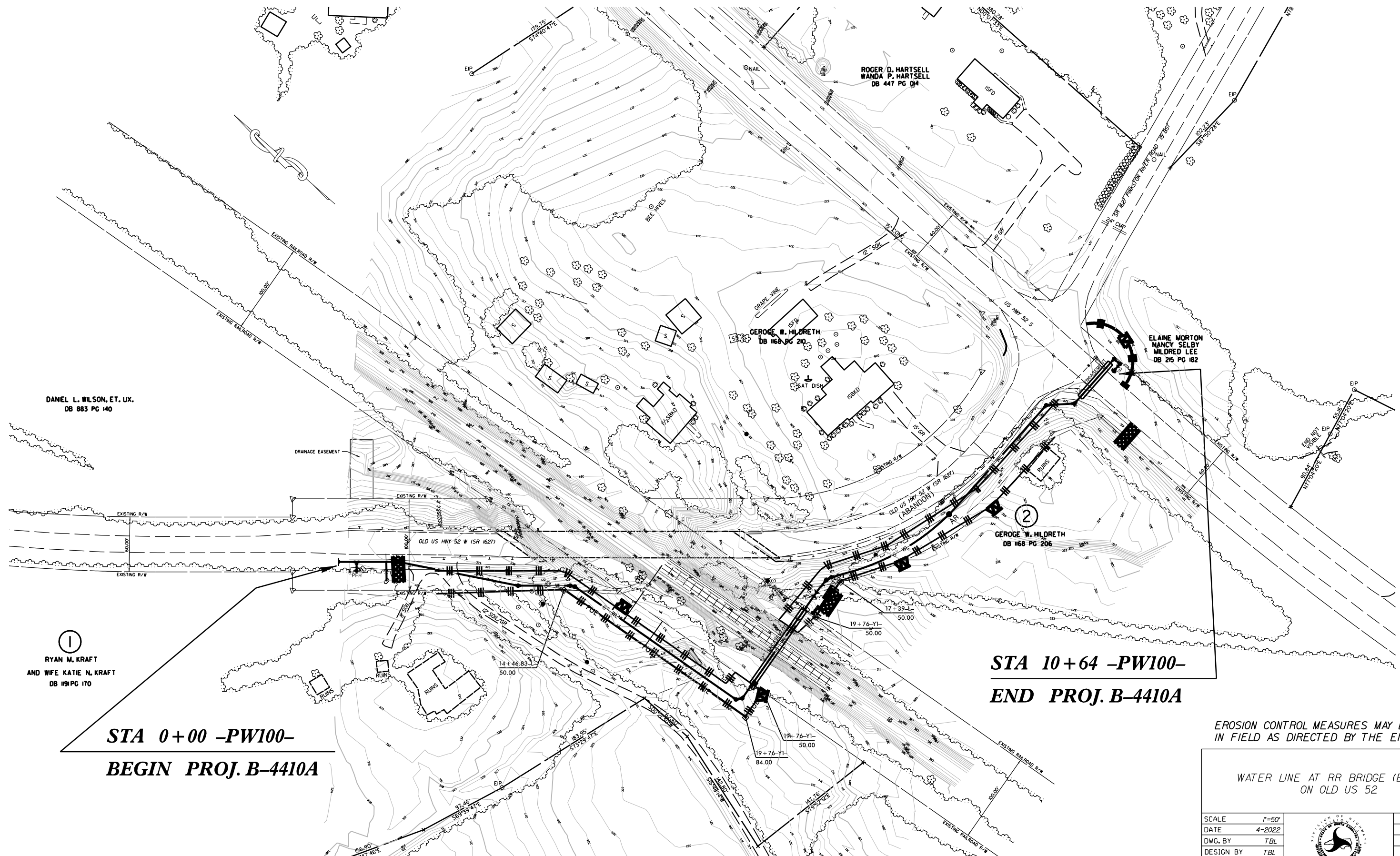

DANIEL L. WILSON, ET. UX.
DB 883 PG 140

ROGER D. HARTSELL
WANDA P. HARTSELL
DB 447 PG 04

GEORGE W. HILDRETH
DB 168 PG 210

ELAINE MORTON
NANCY SELBY
MILDRED LEE
DB 265 PG 182

RYAN M. KRAFT
AND WIFE KATIE N. KRAFT
DB 119 PG 170

**STA 0+00 -PW100-
BEGIN PROJ. B-4410A**

**STA 10+64 -PW100-
END PROJ. B-4410A**

EROSION CONTROL MEASURES MAY BE CHANGED,
IN FIELD AS DIRECTED BY THE ENGINEER.

WATER LINE AT RR BRIDGE (B-4410A) ON OLD US 52			REVISIONS
SCALE	r=50'		
DATE	4-2022		
DWG. BY	TBL		
DESIGN BY	TBL		
APPROVED	JDH		

PROJECT NO.	SHEET NO.
33688.3.2	EC-4A
F.A. PROJECT NO.	

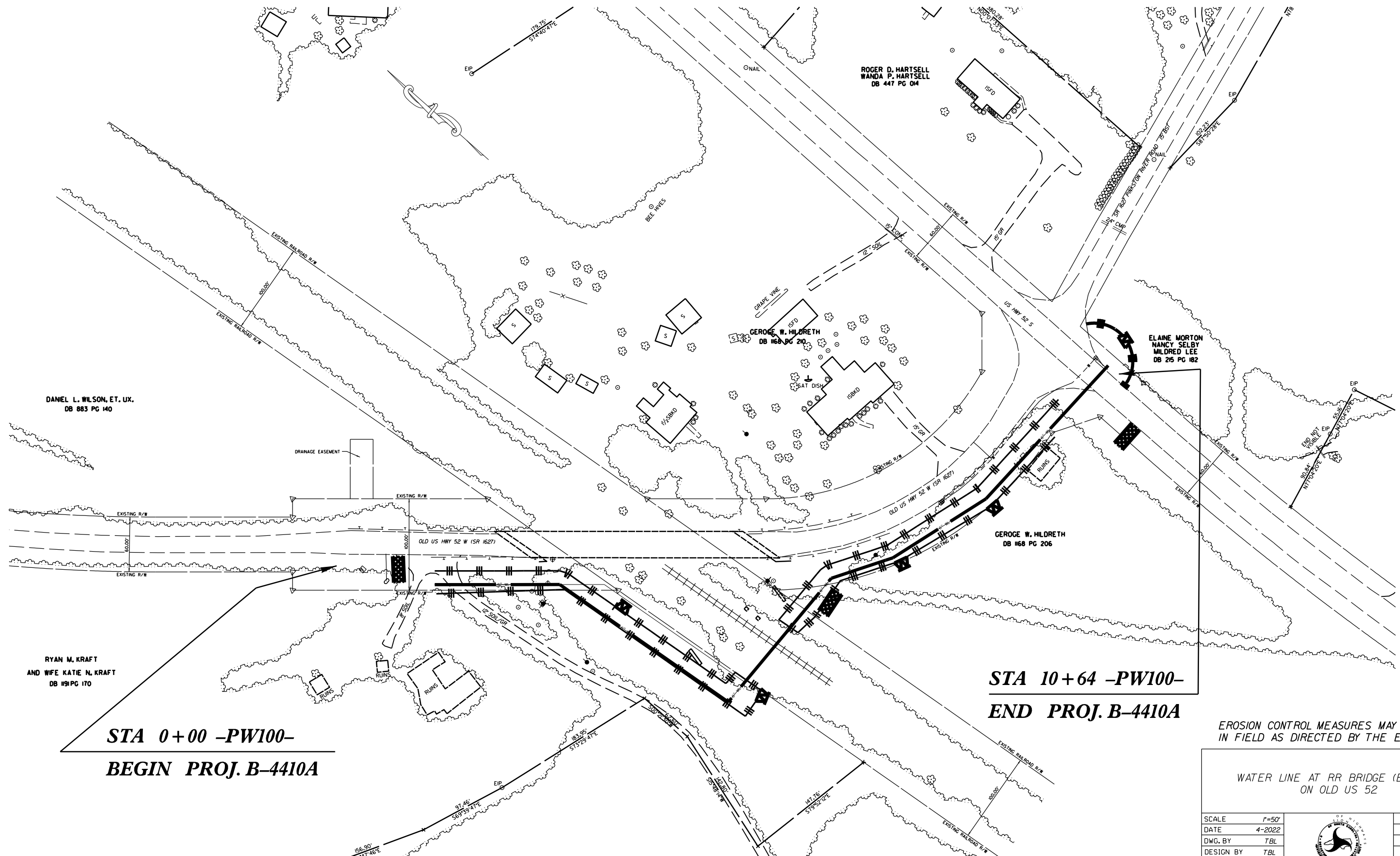

**STA 0+00 -PW100-
BEGIN PROJ. B-4410A**

**STA 10+64 -PW100-
END PROJ. B-4410A**

EROSION CONTROL MEASURES MAY BE CHANGED,
IN FIELD AS DIRECTED BY THE ENGINEER.

WATER LINE AT RR BRIDGE (B-4410A)
ON OLD US 52

SCALE	1"=50'		REVISIONS
DATE	4-2022		
DWG. BY	TBL		
DESIGN BY	TBL		
APPROVED	JDH		